

ELECTRIC PUMP EL35S

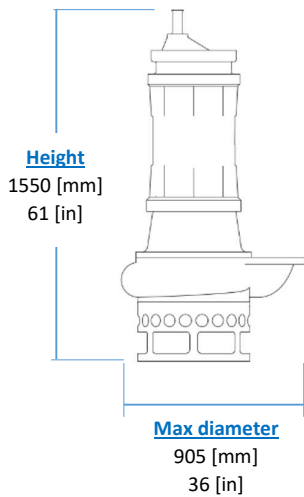
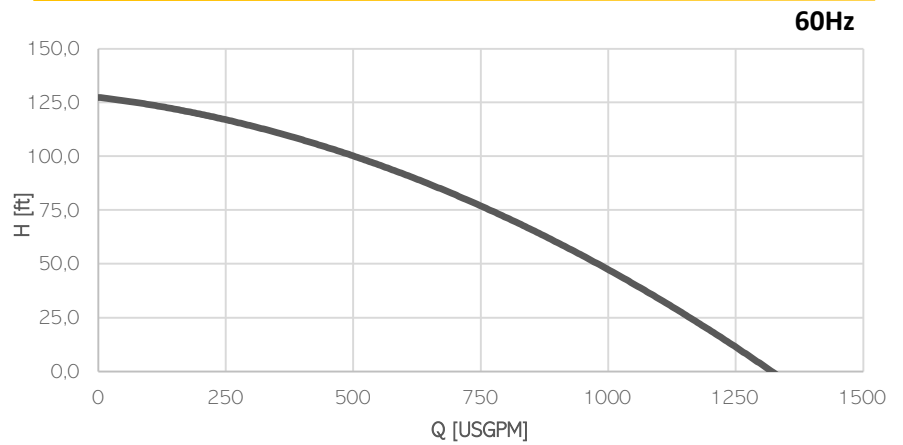

KG
Weight
(without cable)
780 [kg]
1580 [lb]

Model	EL35S
Brake Power [kW HP]	45 60
Electric Power [kW HP]	49 66
Frequency [Hz]	60
Efficiency [%]	52%
Number of Poles	6
RPM	1164
Voltage [V]	575
Rated Current [A]	63,2
Solid handling [mm in]	35 1.4
Discharge [DN-PN]	100-10

Materials

Part	Standard
Casing	Cast Iron EN-GJS500
Body	Cast Iron EN-GJL250
Wear Parts	High chrome EN-GJN-HV600 (CH6)
Minimum hardness [HB]	550
Main shaft	High tensile 39NiCrMo3
PH Range	5-10

Seals and lubricants

Version	-	MG	MS
Motor Side	-	MECHANICAL	MECHANICAL
Impeller Side	-	LIPS	MECHANICAL
Oil type	-	ISO32	ISO32

Electrical motor

Insulation class H

Cable

1 x SHD-GC cable 15m (50ft)

Operating Conditions

- Max liquid temperature 35°C
- Min Submersion depth 1240 mm