

ELECTRIC PUMP

EL200

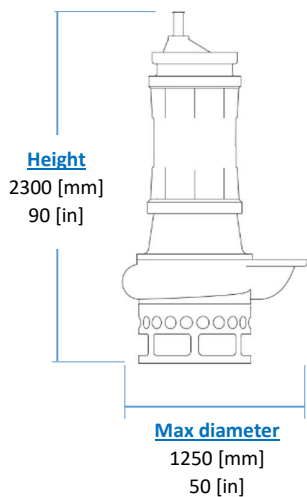
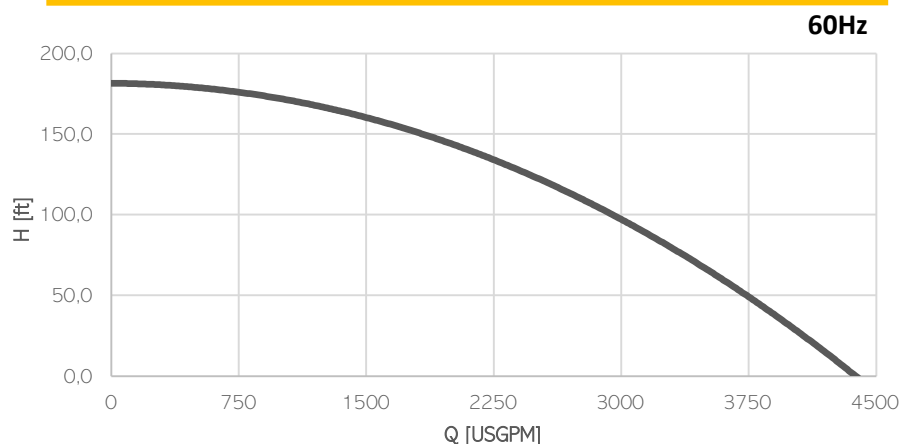

KG
Weight
(without cable)
3000 [kg]
6600 [lb]

Model	EL200
Brake Power [kW HP]	150 201
Electric Power [kW HP]	159 213
Frequency [Hz]	60
Efficiency [%]	55%
Number of Poles	6
RPM	1176
Voltage [V]	575
Rated Current [A]	188,0
Solid handling [mm in]	60 2.4
Discharge [DN-PN]	200-10

Materials

Part	Standard
Casing	Cast Iron EN-GJS500
Body	Cast Iron EN-GIL250
Wear Parts	High chrome EN-GJN-HV600 (CH6)
Minimum hardness [HB]	550
Main shaft	High tensile 39NiCrMo3
PH Range	5-10

Seals and lubricants

Version	-	-	MS
Motor Side	-	-	MECHANICAL
Impeller Side	-	-	MECHANICAL
Oil type	-	-	ISO32

Electrical motor

Insulation class H

Cable

1 x SHD-GC cable 15m (50ft)

Operating Conditions

- Max liquid temperature 35°C
- Min Submersion depth 1820 mm