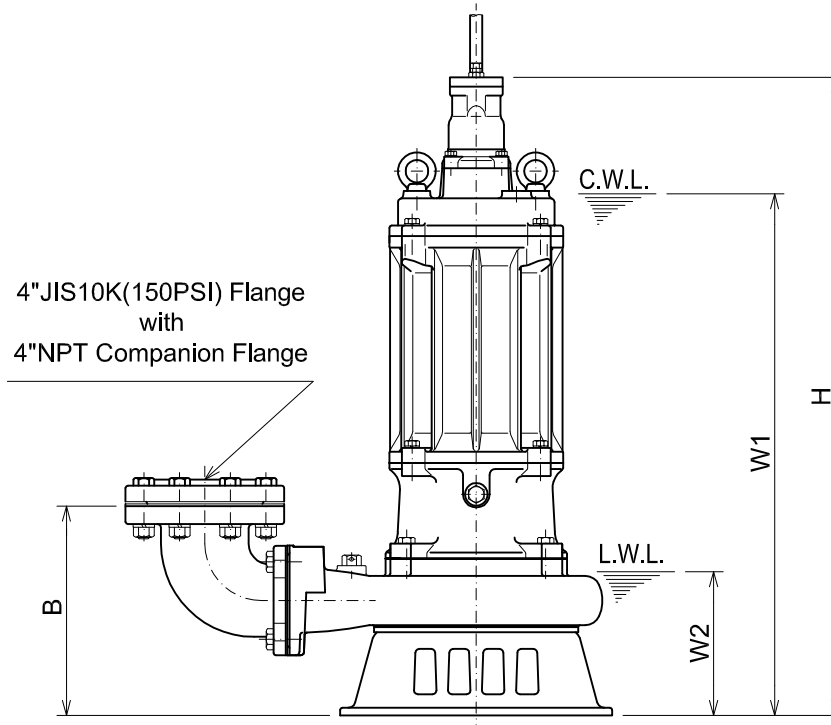
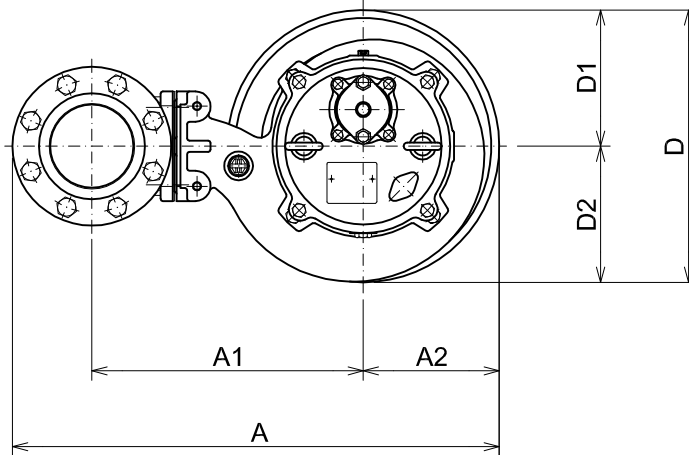

100SFQ25.5 -62
100SFQ27.5 -62

C.W.L. :Continuous running Water Level
 L.W.L. :Lowest running Water Level

DIMENSIONS:USCS(Inch)

Model	HP	NOM. SIZE	Pump & Motor								C.W.L.	L.W.L.	Wt. (lbs.)
			A	A1	A2	B	D	D1	D2	H			
100SFQ25.5 -62	7.5	4"	25 3/8	14 1/8	7 1/16	10 7/8	14 3/16	7 1/16	7 1/16	33 1/4	27 1/8	7 1/2	278
100SFQ27.5 -62	10	4"	25 3/8	14 1/8	7 1/16	10 7/8	14 3/16	7 1/16	7 1/16	33 1/4	27 1/8	7 1/2	276

DIMENSIONS:METRIC(mm)

Model	kW	NOM. SIZE	Pump & Motor								C.W.L.	L.W.L.	Wt. (kg)
			A	A1	A2	B	D	D1	D2	H			
100SFQ25.5 -62	5.5	100	644	359	180	277	360	180	180	844	690	190	126
100SFQ27.5 -62	7.5	100	644	359	180	277	360	180	180	844	690	190	125