



**C-SERIES
CUTTER - TYPE - SEWAGE & WASTEWATER PUMPS**

DIMENSIONS

100C42.2-CR -62

Bend model:
BEND80-100 ANSI

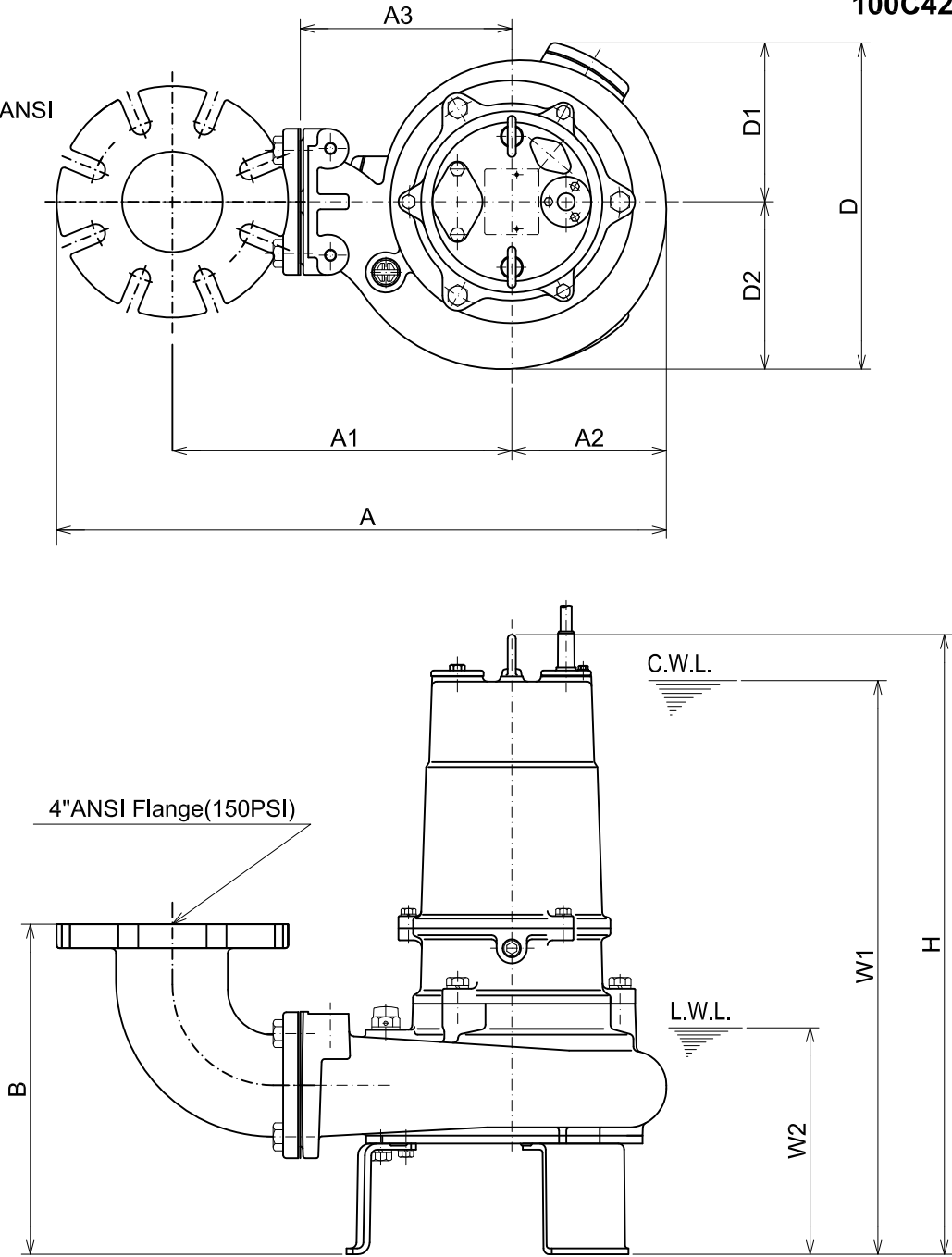

C.W.L. :Continuous running Water Level
L.W.L. :Lowest running Water Level

DIMENSIONS:USCS(Inch)

Model	HP	NOM. SIZE	Pump & Motor									C.W.L. W1	L.W.L. W2	*Wt. (lbs.)
			A	A1	A2	A3	B	D	D1	D2	H			
100C42.2-CR -62	3	4"	24 3/16	13 9/16	6 1/16	8 1/4	12 15/16	12 3/4	6 1/4	6 9/16	24 1/4	22 1/2	8 7/8	148

*Excluding Cable.

DIMENSIONS:METRIC(mm)

Model	kW	NOM. SIZE	Pump & Motor									C.W.L. W1	L.W.L. W2	*Wt. (kg)
			A	A1	A2	A3	B	D	D1	D2	H			
100C42.2-CR -62	2.2	100	614	345	154	210	328	324	158	166	616	570	225	67