

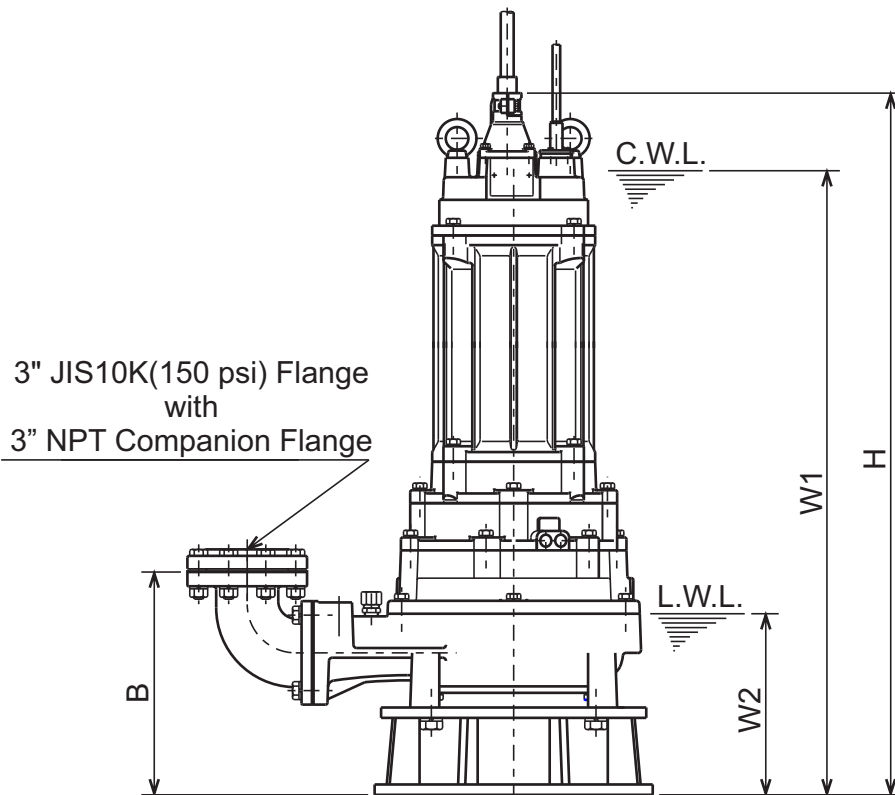

C - SERIES
CUTTER-TYPE - SEWAGE & WASTEWATER PUMPS

DIMENSIONS

80C215-CR-61

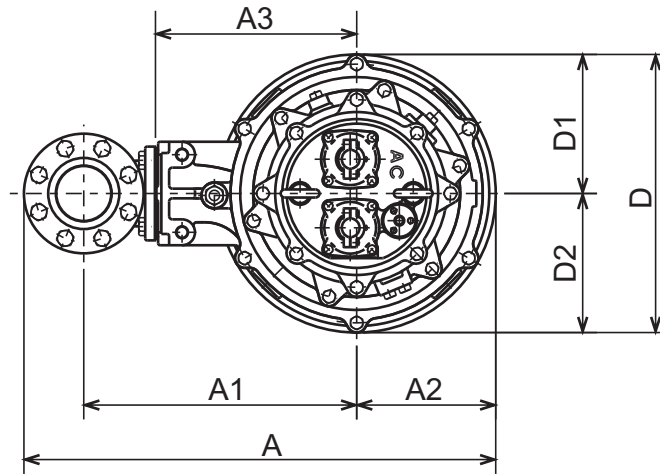

3" JIS10K(150 psi) Flange with
3" NPT Companion Flange

C.W.L. : Continuous running Water Level
L.W.L. : Lowest running Water Level

DIMENSIONS:USCS (Inch)

Model	HP	NOM. SIZE	Pump & Motor									C.W.L. W1	L.W.L. W2	Wt. (lbs.)
			A	A1	A2	A3	B	D	D1	D2	H			
80C215-CR-61	20	3"	28 3/4	16 1/2	8 7/16	12 3/16	13 5/8	16 15/16	8 7/16	8 1/2	42 3/4	38	11	560

DIMENSIONS:METRIC (mm)

Model	kW	NOM. SIZE	Pump & Motor									C.W.L. W1	L.W.L. W2	Wt. (kg)
			A	A1	A2	A3	B	D	D1	D2	H			
80C215-CR-61	15	80	730	422	215	310	345	430	215	215	1085	965	280	255

*Excluding Cable