



TSURUMI PUMP

**C-SERIES
CUTTER - TYPE - SEWAGE & WASTEWATER PUMPS**

DIMENSIONS

TOS80C21.5-CR -62

Guide Rail System
Model : TOS3-80-80 ANSI
Wt. : 64lb.(29kg)

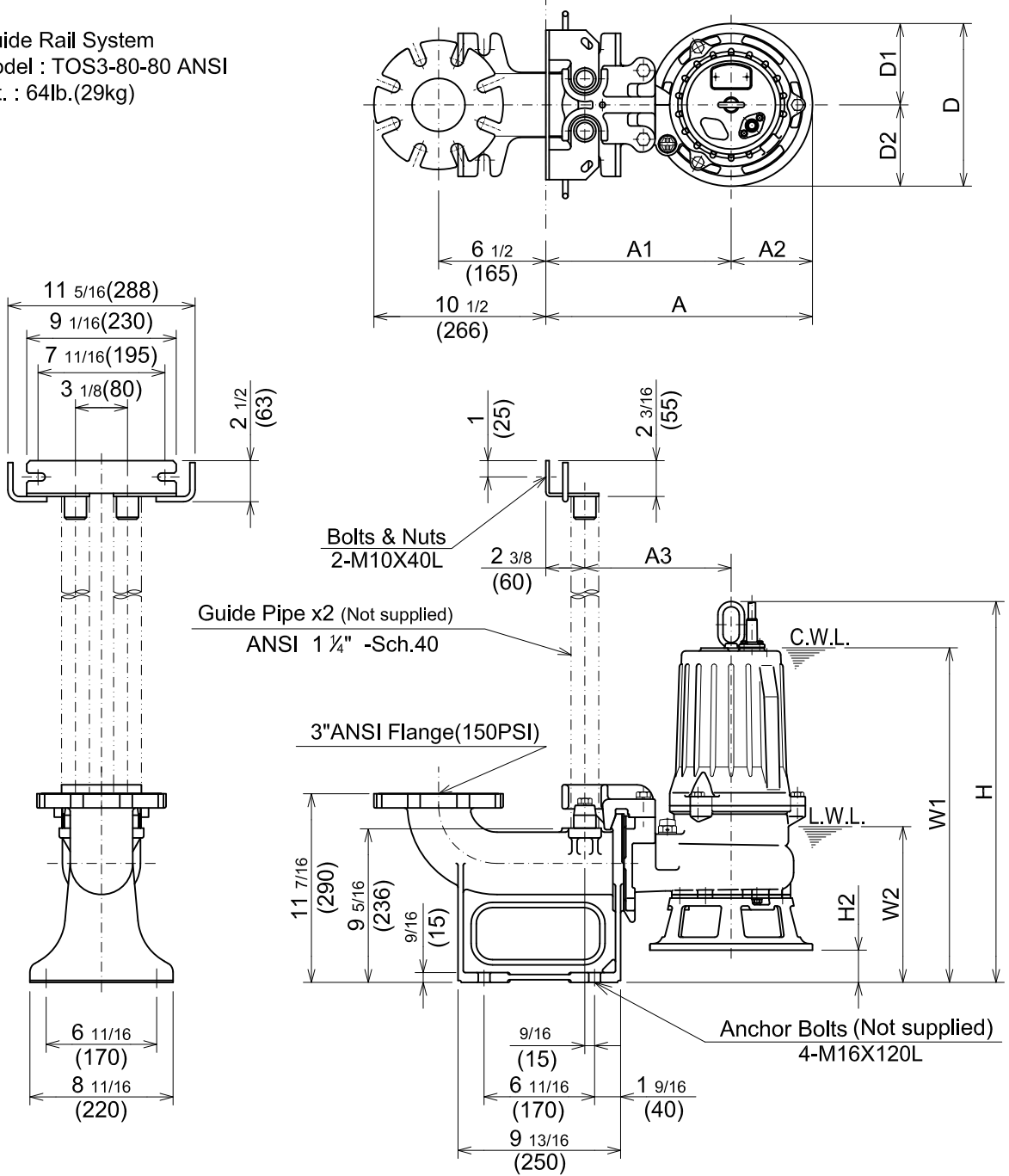

C.W.L. :Continuous running Water Level
L.W.L. :Lowest running Water Level

DIMENSIONS:USCS(Inch)

Model	HP	NOM. SIZE	Pump & Motor									C.W.L.	L.W.L.	*Wt. (lbs.)
			A	A1	A2	A3	D	D1	D2	H	H2			
TOS80C21.5-CR -62	2	3"	16 1/8	11 1/4	4 15/16	8 7/8	9 13/16	4 15/16	4 15/16	23 1/16	1 15/16	20 1/4	9 1/2	75

DIMENSIONS-METRIC(mm)

Model	KW	NOM. SIZE	Pump & Motor									C.W.L.	L.W.L.	*Wt. (kg)
			A	A1	A2	A3	D	D1	D2	H	H2			
TOS80C21.5-CR -62	1.5	80	410	285	125	225	250	125	125	586	50	515	240	34

*Excluding TOS & Cable.