

TM03 1454 2205

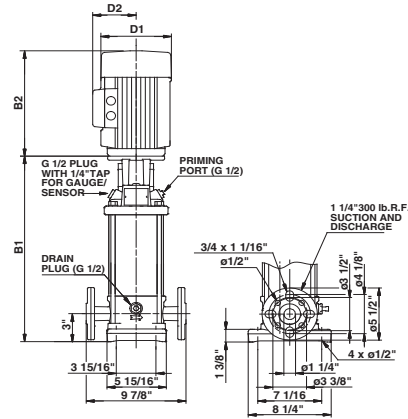

TM03 1453 2205

Pump type	P2 [hp]	Ph.	PJE*	ANSI dimensions [inch]				Ship Wt. [lbs.]	ANSI dimensions [inch]						
				B1	TEFC				D1	D2	B1+B2	D1	MLE		Ship Wt. [lbs.]
					D1	D2	B1+B2						D1	D2	
CRN 1-2	1/3	1	•	12.09	6.19	5.18	21.38	64	-	-	-	-			
		3	•	12.09	5.55	4.57	19.53	62	-	-	-	-			
CRN 1-3	1/3	1	•	12.09	6.19	5.18	21.38	64	-	-	-	-			
		3	•	12.09	5.55	4.57	19.53	62	-	-	-	-			
CRN(E) 1-4	1/2	1	•	12.80	6.19	5.18	22.09	68	5.55	5.51	20.22	65			
		3	•	12.80	5.55	4.57	20.24	63	-	-	-	-			
CRN 1-5	1/2	1	•	13.50	6.19	5.18	22.79	69	-	-	-	-			
		3	•	13.50	5.55	4.57	20.94	64	-	-	-	-			
CRN(E) 1-6	3/4	1	•	14.21	6.19	5.18	24.12	74	5.55	5.51	21.63	68			
		3	•	14.21	5.55	4.57	21.65	65	-	-	-	-			
CRN 1-7	3/4	1	•	14.92	6.19	5.18	24.83	75	-	-	-	-			
		3	•	14.92	5.55	4.57	22.36	66	-	-	-	-			
CRN 1-8	1	1	•	15.63	7.19	5.73	26.82	88	-	-	-	-			
		3	•	15.63	5.55	4.57	23.07	67	-	-	-	-			
CRN(E) 1-9	1	1	•	16.34	7.19	5.73	27.53	89	5.55	5.51	25.32	73			
		3	•	16.34	5.55	4.57	23.78	68	7.01	6.57	29.14	90			
CRN(E) 1-10	1 1/2	1	•	17.05	7.19	5.73	28.73	90	-	-	-	-			
		3	•	17.05	5.55	4.57	25.67	69	7.01	6.57	29.85	92			
CRN 1-11	1 1/2	1	•	17.76	7.19	5.73	29.44	97	-	-	-	-			
		3	•	17.76	5.55	4.57	26.38	70	-	-	-	-			
CRN 1-12	1 1/2	1	•	18.46	7.19	5.73	30.14	98	-	-	-	-			
		3	•	18.46	5.55	4.57	27.08	71	-	-	-	-			
CRN(E) 1-13	1 1/2	1	•	19.17	7.19	5.73	30.85	99	5.55	5.51	28.15	80			
		3	•	19.17	5.55	4.57	27.79	72	7.01	6.57	31.97	97			
CRN(E) 1-15	2	1	•	20.59	7.19	5.73	33.15	108	-	-	-	-			
		3	•	20.59	7.01	4.33	31.81	99	7.01	6.57	33.39	112			
CRN(E) 1-17	2	1	•	22.01	7.19	5.73	34.57	110	-	-	-	-			
		3	•	22.01	7.01	4.33	33.23	101	7.01	6.57	34.81	113			
CRN 1-19	3	1	•	23.43	8.60	6.87	38.08	148	-	-	-	-			
		3	•	23.43	7.01	4.33	36.66	116	-	-	-	-			
CRN 1-21	3	1	•	25.94	8.60	6.87	40.59	150	-	-	-	-			
		3	•	25.94	7.01	4.33	39.17	118	-	-	-	-			
CRN(E) 1-23	3	1	•	27.36	8.60	6.87	42.01	152	-	-	-	-			
		3	•	27.36	7.01	4.33	40.59	123	7.01	6.57	40.67	131			
CRN 1-25	3	1	•	28.78	8.60	6.87	43.43	154	-	-	-	-			
		3	•	28.78	7.01	4.33	42.01	124	-	-	-	-			
CRN(E) 1-27	3	1	•	30.20	8.60	6.87	44.85	155	-	-	-	-			
		3	•	30.20	7.01	4.33	43.43	126	7.01	6.57	43.51	135			

All dimensions in inches unless otherwise noted.

\*PJE flanged pump B1 and B1+B2 dimension is one inch less than ANSI flanged pump and weight is approximately 9 lbs. less.

- Available